



## HYTORC GRIP-TIGHT™ NUT

### HYTORC Part Number: HGTN-M22

Protect your commercial fleet from wheel installation related incidents with the new HYTORC GRIP-TIGHT™ Nut. The GRIP-TIGHT™ Nut is an instant upgrade for all heavy-duty truck and trailer hub piloted wheels. The patent pending GRIP-TIGHT™ Nut eliminates the influence of side loads and provides a pinch point free reaction component for applied torque. The GRIP-TIGHT™ Nut allows for controlled and safe torqueing with HYTORC Electric Torque tools. Call to request a demonstration of HYTORC cordless tooling system in conjunction with the GRIP-TIGHT™ Nut.

#### MATERIALS



Made-in-the-USA, the GRIP-TIGHT™ Nut is produced from through-hardened carbon steel and each free spinning washer is made from through-hardened and tempered chrome-moly steel. The GRIP-TIGHT™ Nut geometry and coatings combine to create a consistent and efficient translation from torque to clamping force.

#### SPECIFICATIONS



GRIP-TIGHT™ Nuts have M22X1.5 threads, 33mm hex, 27mm height and a 46mm washer diameter. The two-piece GRIP-TIGHT™ Nuts comply with technical requirements of SAE J1965. Cross Reference PN's: 39773, 39874, 39702, M3979, 39691, 39949, 201.3013, 13-3057, E-9020, W-525, R009020, 511034, KB9020, WA075037, 20857204, 1649492C1, E6HZ-1120-A, MF110343, and MF111026.

#### TOOLING



GRIP-TIGHT™ Nuts can be torqued and loosened with common impact guns and wrenches. The patent pending washer profile includes a special geometry for rotationally coupling to the HYTORC reaction socket. This washer acts as a coaxial reaction point, thereby eliminating pinch points and removing undesirable side loads. These benefits make it feasible to upgrade to cordless digital tooling systems while increasing the efficiency, quality and safety of wheel nut installations.

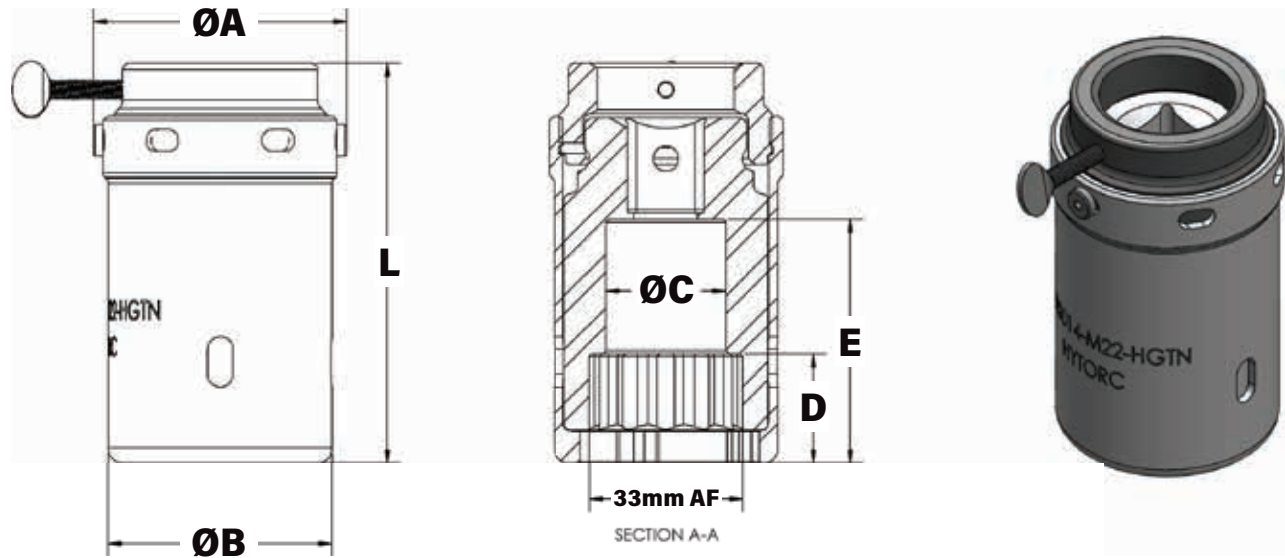

LEGEND : ØA = OUTER DIAMETER ØB= DIAMETER AT WRENCH END ØC = DIAMETER DEEP WELL L= LENGTH D = DEPTH OF HEX SOCKET E = BOLT CLEARANCE DEPTH

| PART NUMBER     | ØA    | ØB    | ØC    | L     | D     | E     | SQUARE DRIVE | WEIGHT |  |
|-----------------|-------|-------|-------|-------|-------|-------|--------------|--------|--|
| <b>IMPERIAL</b> |       |       |       | in.   |       |       |              | lbs.   |  |
| DZAK-HGTN-M22   | 2.490 | 2.205 | 2.031 | 3.937 | 1.076 | 2.402 | 3/4          | 2.600  |  |
| <b>METRIC</b>   |       |       |       | mm    |       |       |              | kg     |  |
| DZAK-HGTN-M22   | 63    | 56    | 30    | 100   | 27    | 61    | 19           | 1.17   |  |

## FLEET MAINTENANCE BOLTING TECHNOLOGY

The HYTORC GRIP-TIGHT™ NUT can be torqued using the proprietary GRIP-TIGHT™ DRIVER part DZAK-HGTN-M22 with next-generation portable electric torque tools such as HYTORC LION GUN® or HYTORC flagship LITHIUM SERIES® II Electric Torque tool.

### LITHIUM SERIES® II



### LION GUN® USING GRIP-TIGHT NUT DRIVER



HYTORC owns all content, copyrights, trademarks and patents in this document. © 2021 HYTORC. Any unauthorized use or distribution of any material from this document is strictly prohibited.

**HYTORC**

**Headquarters:**  
333 Route 17 N., Mahwah, NJ 07430  
+1-201-512-9500

**Email:**  
info@hytorc.com

**Phone:**  
1-800-FOR-HYTORC

**Online:**  
hytorc.com